



**3", 4", 6" & 8"  
Model H Series  
Alarm Check Valve  
Installation  
and  
Maintenance Guide**

4077 AIRPARK DRIVE • STANDISH, MICHIGAN 48658  
PHONE 989-846-4583 • 800-248-0278  
FAX 989-846-9231 • 800-846-9211  
[www.globesprinkler.com](http://www.globesprinkler.com)  
[www.globe\\_man@msn.com](mailto:www.globe_man@msn.com)

# GLOBE ALARM CHECK VALVE INSTALLATION AND MAINTENANCE GUIDE

## Table of Contents

Globe Alarm Check Valves	1
General Description	1
Physical Data	2
3", 4" & 6" Alarm Check Valve Assembly and Parts List	3
8" Alarm Check Valve Assembly and Parts List	3
3" Model H Series Vertical Position / Variable Pressure Trim	6
3" Model H Series Vertical Position / Constant Pressure Trim	7
3" Model H Series Horizontal Position / Variable Pressure Trim	8
3" Model H Series Horizontal Position / Constant Pressure Trim	9
4" Model H Series Vertical Position / Variable Pressure Trim	10
4" Model H Series Vertical Position / Constant Pressure Trim	11
4" Model H Series Horizontal Position / Variable Pressure Trim	12
4" Model H Series Horizontal Position / Constant Pressure Trim	13
6" Model H Series Vertical Position / Variable Pressure Trim	14
6" Model H Series Vertical Position / Constant Pressure Trim	15
6" Model H Series Horizontal Position / Variable Pressure Trim	16
6" Model H Series Horizontal Position / Constant Pressure Trim	17
8" Model H Series Vertical Position / Variable Pressure Trim	18
8" Model H Series Vertical Position / Constant Pressure Trim	19
Optional Alarm Pressure Switch Trim	20
Pressure Relief Valve for Use in Gridded Systems	20
Testing	4
Maintenance	5

# **GLOBE ALARM CHECK VALVE INSTALLATION AND MAINTENANCE GUIDE**

## **GENERAL DESCRIPTION**

Globe Fire Sprinkler Corporation Alarm Check Valves are used in wet pipe fire sprinkler systems. They primarily serve a dual purpose in that they prevent a reverse flow of water through their bodies (non-return) and also provide for the use of a hydraulic fire alarm which is not dependent upon an electrical power supply for its operation. Through the use of a hydraulic retard chamber a time delay is provided to eliminate potential false alarms caused by fluctuating water supply pressures. Where constant pressure water supplies are used the retard chamber (time delay) is not necessary. By incorporating the use of electrical pressure switches, other supplemental alarms, annunciators, etc. may also be used.

Globe Alarm Check Valves are designed and manufactured to the standards and/or requirements of Underwriters Laboratories Inc., Factory Mutual Approvals, The Loss Prevention Certification Board and the City of New York Department of Buildings, and they conform to the design/usage requirements of NFPA 13.

## **IMPORTANT NOTES**

1. Any alarm check valve should be carefully tested, examined, and cleaned periodically in accordance with NFPA 25.
2. It is most important to ensure a clean water supply free of debris and solid particles such as sand, gravel, or mud.
3. If, during the annual inspection of alarm check valves, sediment or free particles of matter are noted, a further examination of internal valve parts becomes necessary.
4. All deposits should be removed from all operating parts and ports. Vent holes through seat ring, Items 3 and 2 (Page 4), should be thoroughly cleaned and flushed with clean water.
5. Where difficulty in performance is experienced, the manufacturer or his authorized representative shall be contacted if any field adjustment is to be made.

# GLOBE ALARM CHECK VALVE INSTALLATION AND MAINTENANCE GUIDE

## PHYSICAL DATA

VERTICAL / VARIABLE										
MODEL	H-1				H-2		H-3			
SIZE	3"	4"	6"	8"	3"	4"	3"	4"	6"	8"
Overall Length	9"	9"	10"	14"	10"	10"	9 1/4"	9 1/2"	11"	13 5/8"
Center of Valve to Back	10"	11"	12"	13"	10"	11"	10"	11"	12"	13"
Center of Valve to Right	13 1/2"	16 1/2"	16 1/2"	16 1/2"	13 1/2"	16 1/2"	13 1/2"	16 1/2"	16 1/2"	16 1/2"
Center of Valve to Left	8"	8"	8"	8"	8"	8"	8"	8"	8"	8"
Center of Valve to Center of Drain	9 1/4"	8"	8 3/4"	8 3/4"	9 1/4"	8"	9 1/4"	8"	8 3/4"	8 3/4"
Weight of Valve	34 lbs.	42 lbs.	69 lbs.	147 lbs.	20 lbs.	22 lbs.	28 lbs.	37 lbs.	59 lbs.	147 lbs.
Complete with all Trimmings	81 lbs.	89 lbs.	114 lbs.	192 lbs.	57 lbs.	69 lbs.	75 lbs.	84 lbs.	100 lbs.	196 lbs.
VERTICAL / CONSTANT										
MODEL	H-1				H-2		H-3			
SIZE	3"	4"	6"	8"	3"	4"	3"	4"	6"	8"
Overall Length	9"	9"	10"	14"	10"	10"	9 1/4"	9 1/2"	11"	13 5/8"
Center of Valve to Back	10"	8 3/4"	9 3/4"	12 1/4"	10"	8 3/4"	10"	8 3/4"	9 3/4"	12 1/4"
Center of Valve to Right	13 1/2"	15 1/2"	16 1/4"	17"	13 1/2"	15 1/2"	13 1/2"	15 1/2"	16 1/4"	17"
Center of Valve to Left	8"	8"	8"	7 1/2"	8"	8"	8"	8"	8"	7 1/2"
Center of Valve to Center of Drain	9 1/4"	8"	8 3/4"	9 1/2"	9 1/4"	8"	9 1/4"	8"	8 3/4"	9 1/2"
Weight of Valve	34 lbs.	42 lbs.	69 lbs.	147 lbs.	20 lbs.	22 lbs.	28 lbs.	37 lbs.	59 lbs.	147 lbs.
Complete with all Trimmings	56 lbs.	64 lbs.	89 lbs.	167 lbs.	32 lbs.	44 lbs.	50 lbs.	59 lbs.	75 lbs.	172 lbs.
HORIZONTAL / VARIABLE										
MODEL	H-1				H-2		H-3			
SIZE	3"	4"	6"	8"	3"	4"	3"	4"	6"	8"
Overall Length	9"	9"	10"	N/A	10"	10"	9 1/4"	9 1/2"	11"	N/A
Center of Valve to Back	7 1/2"	27"	20 1/2"	N/A	7 1/2"	27"	7 1/2"	27"	20 1/2"	N/A
Center of Valve to Right	17 1/2"	17"	18 1/2"	N/A	17 1/2"	17"	17 1/2"	17"	18 1/2"	N/A
Center of Valve to Left	7 1/4"	8 1/2"	12"	N/A	7 1/4"	8 1/2"	7 1/4"	8 1/2"	12"	N/A
Center of Valve to Center of Drain	9 1/2"	13 1/2"	14"	N/A	9 1/2"	13 1/2"	9 1/2"	13 1/2"	14"	N/A
Weight of Valve	34 lbs.	42 lbs.	69 lbs.	N/A	20 lbs.	22 lbs.	28 lbs.	37 lbs.	59 lbs.	N/A
Complete with all Trimmings	89 lbs.	97 lbs.	122 lbs.	N/A	70 lbs.	82 lbs.	83 lbs.	92 lbs.	113 lbs.	N/A
HORIZONTAL / CONSTANT										
MODEL	H-1				H-2		H-3			
SIZE	3"	4"	6"	8"	3"	4"	3"	4"	6"	8"
Overall Length	9"	9"	10"	N/A	10"	10"	9 1/4"	9 1/2"	11"	N/A
Center of Valve to Back	7 1/2"	24 1/2"	19 1/2"	N/A	7 1/2"	24 1/2"	7 1/2"	24 1/2"	19 1/2"	N/A
Center of Valve to Right	17 1/2"	16 1/2"	15 1/2"	N/A	17 1/2"	16 1/2"	17 1/2"	16 1/2"	15 1/2"	N/A
Center of Valve to Left	7 1/4"	8 1/2"	8 3/4"	N/A	7 1/4"	8 1/2"	7 1/4"	8 1/2"	8 3/4"	N/A
Center of Valve to Center of Drain	12 1/4"	13 1/2"	14"	N/A	12 1/4"	13 1/2"	12 1/4"	13 1/2"	14"	N/A
Weight of Valve	34 lbs.	42 lbs.	69 lbs.	N/A	20 lbs.	22 lbs.	28 lbs.	37 lbs.	59 lbs.	N/A
Complete with all Trimmings	60 lbs.	68 lbs.	94 lbs.	N/A	70 lbs.	53 lbs.	54 lbs.	63 lbs.	85 lbs.	N/A

# GLOBE ALARM CHECK VALVE INSTALLATION AND MAINTENANCE GUIDE

## 3", 4" & 6" ALARM CHECK VALVE ASSEMBLY

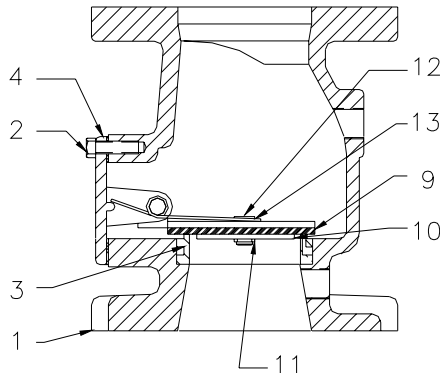

**FRONT VIEW**

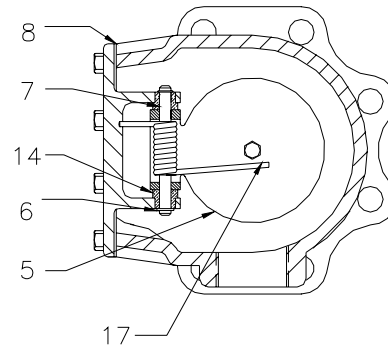

**TOP VIEW**

ITEM	DESCRIPTION	MAT'L	3" P/N	4" P/N	6" P/N	ITEM	DESCRIPTION	MAT'L	3" P/N	4" P/N	6" P/N
1	Body - H-1	Cast Iron	323803	323502	323562	9	Clapper Facing Disc	EPDM	323815	323511	323571
	Body H-2	Cast Iron	323827	323552	-----	10	Disc Retainer	Stainless	323816	323512	323572
	Body - H-3	Cast Iron	323807	323542	323592	11	Lock Nut	Stainless	323514	323514	323514
2	Cover Bolt	Steel	323408	323509	323569	12	Disc Retainer Bolt	Stainless	323817	323513	323573
3	Seat Ring	Bronze	323809	323504	323564	13	Sealing Washer	Hard Fiber	323515	323515	323515
4	Cover	Cast Iron	323805	323507	323567	14	Hinge Pin Bushing	Bronze	323819	323518	323518
5	Clapper	Stainless	323814	323510	323570	15	Name Plate	Aluminum	323480	323480	323480
6	Retaining Ring	Stainless	323527	323517	323517	16	Drive Screw	Stainless	323520	323520	323520
7	Hinge Pin	Stainless	323818	323516	323516	17	Torsion Spring	Stainless	323528	323528	323565
8	Cover Gasket	Vellumoid	323810	323508	323568	18	Spring Bushing	Brass	-----	-----	323579

## 8" ALARM CHECK VALVE ASSEMBLY

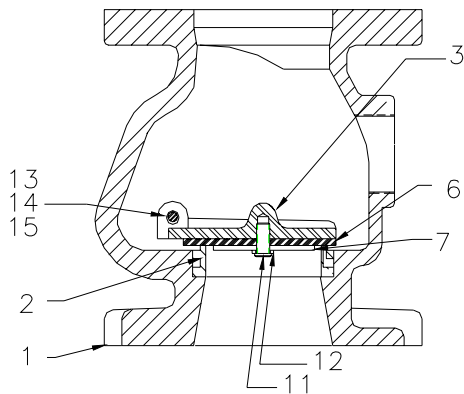

**FRONT VIEW**

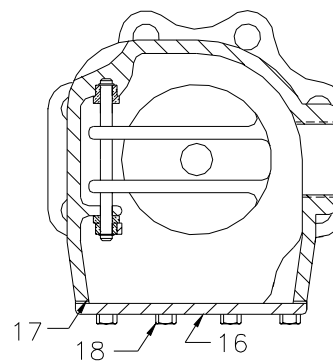

**TOP VIEW**

ITEM	DESCRIPTION	MAT'L	P/N	ITEM	DESCRIPTION	MAT'L	P/N
1	Body - H-1	Cast Iron	323832	7	Clapper Disc	EPDM	323842
	Body - H-3	Cast Iron	323851	8	Disc Retainer	Stainless	323843
2	Cover	Cast Iron	323835	9	Disc Retainer Bolt	Stainless	323838
3	Cover Gasket	Rubber	323833	10	Hinge Pin	Stainless	323845
4	Cover Bolt	Steel	323839	11	Hinge Pin Bushing	Bronze	323846
5	Seat Ring	Bronze	323837	12	Name Plate	Aluminum	323480
6	Clapper	Bronze	323841	13	Drive Screw	Stainless	323420

# GLOBE ALARM CHECK VALVE INSTALLATION AND MAINTENANCE GUIDE

## Testing and Maintenance

### Reference

NFPA 25, Standard for the Inspection, Testing, and Maintenance of Water-Based Fire Protection Systems.

### TESTING

Before proceeding with any tests involving water flow, certain precautions need to be taken.

1. Check the location where the test connection discharges to make sure that all is clear and that there is no possibility of the water flow causing damage or injury.
2. Check the end of the test connection to make sure that it is unobstructed. To obtain a satisfactory test, there must be an unrestricted flow of water when the test valve is wide open.
3. Check for alarm connections to a central station or fire department. If such connections are found, give proper notice to the signal receiving station before proceeding with the test.

**Note:** A main drain test will also operate local fire alarms - unless they are temporarily shut off.

### Testing Alarm Valve and Waterflow Alarm Devices

NFPA 25 recommends that the alarm valve and its waterflow alarm devices be tested at least quarterly.

The primary way to test this equipment is by opening the Inspectors Test Connection. This connection, generally located at the highest and most remote point on the system in relation to the alarm valve, consists of a test orifice and controlling globe valve. Opening of the globe valve (Inspectors Test Valve), and the subsequent discharge of water through the test orifice, simulates the operation of a sprinkler. Therefore, alarm devices should sound and/or operate when the Inspectors Test Valve is opened.

An alternate means of testing waterflow alarm devices is to open the Alarm Test Valve provided as part of the alarm valve trim. It must be noted, however, that opening of this valve only tests the alarms; it does not test the operation of the alarm valve since the supply for the alarm test line is taken from a point below the alarm valve clapper (see respective trim drawings). This means of testing, therefore, should only be used when weather conditions or other circumstances prohibit using the Inspectors Test Connection.

**Note:** If alarms connect to a central station or fire department, notify the signal receiving station when all tests have been completed.

### Flow Test at Main Drain Valve (Main Drain Test)

NFPA 25 recommends that a water flow test be made quarterly from the main drain valve at the system riser. The purpose of this test is to show whether or not the normal water supply is available to the system. By comparing static and residual pressure readings with those previously established, a main drain test can indicate the possible presence of closed valves or other obstructions in the supply piping.

The procedure for conducting a Main Drain Test is as follows:

1. With the Main Drain Valve closed, note and record the reading on the lower Pressure Gauge at the Alarm Valve.
2. Open the Main Drain Valve slowly until it is wide open. Then, check to make sure that a full steady flow of water is discharging from the main drain pipe.
3. Allow the water to flow until the reading on the lower Pressure Gauge drops and stabilizes. Then, record this reading.

**Note:** If a full steady stream is not discharging, check the main drain piping further for possible obstructions.

**Note:** The first and higher pressure reading is the static pressure. The second, lower reading is the residual pressure with a given flow discharging from the main drain pipe.

4. Close the Main Drain Valve slowly.

**Caution:** If alarms have been temporarily shut off, they must be returned to service. If alarms connect to a central station or fire department, notify the signal receiving station when the test has been completed.

5. Compare both pressure readings with previously established or normal readings.

**Note:** If the readings compare favorably, the water supply may be considered satisfactory. If, however, the pressure readings vary to any great extent, the condition should be investigated to determine the cause. Some possible causes are:

- Partially or totally closed system control valves.
- Clogged or frozen water mains.
- Serious leakage at valves or mains.

# GLOBE ALARM CHECK VALVE INSTALLATION AND MAINTENANCE GUIDE

## MAINTENANCE

The Globe Alarm Check Valve and its related equipment should be examined periodically to ensure proper operation and trouble-free service. Several areas to be routinely inspected are:

**Clapper Facing.** The rubber clapper facing should be checked for wear or damage, and to determine that it is free of dirt and other foreign substances. If found to be worn or damaged (e.g., foreign matter imbedded in the surface), the facing should be replaced. If it is dirty, it should be cleaned, but compounds which could damage the rubber facing must never be used.

**Seat Ring.** The seat ring should be checked for nicks and for stones, dirt or other foreign matter lodged in the grooves or holes. It should be cleaned thoroughly. If the seat ring is found to be severely damaged, the complete alarm valve assembly should be replaced or returned to Globe for possible reconditioning.

**By-Pass Check Valve.** The 3/4" check valve in the external by-pass should be checked for clapper and seat condition.

**Retard Chamber.** The outlet plug and drain plug assemblies should be checked for obstructions. The screens should be cleaned thoroughly.

**Alarm Line Strainer.** The 3/4" strainer in the alarm line of the constant pressure trim setup should be checked and cleaned thoroughly.

**Alarm Test Valve, Main Drain Valve & Inspectors Test Valve.** All controlling valves which are normally closed when the alarm valve is in the set position should be checked to be sure that they are fully closed and not leaking.

**Alarm Valve & Trim.** The overall setup should be checked for visible leaks and possible physical damage to the valve and connections (e.g., broken gauges).

## Resetting of System

The Globe Alarm Check Valve is self-setting when testing procedures are followed. When sprinklers operate, however, there are certain procedures which must be followed for restoring the system to service.

1. Close the System Control Valve (OS & Y, PIV or other).

**Caution:** In the event of a fire, the system control valve is to be closed only after it has been determined, positively, that the

fire has been extinguished.

2. Close the Alarm Control Valve.

3. Open the Main Drain Valve.

**Note:** It is necessary to drain the system only as required to allow for sprinkler replacement.

4. Replace the sprinklers which have operated.

5. Close the Main Drain Valve

6. Open the Inspectors Test Valve.

**Note:** This valve is opened to permit air to be vented from the system as it is being filled with water.

7. Slowly open the System Control Valve.

**Caution:** Open the valve only partially at the start of water flow into the system. Do not open it fully at this point. To do so may cause a water hammer to occur which could either damage the piping or trap large volumes of air within the system.

8. Continue filling the system until water discharges in a continuous stream from the Inspectors Test Connection.

9. Close the Inspectors Test Valve.

10. Turn the System Control Valve to its full open position, at the same time observing the Pressure Gauges.

**Note:** The system is filled when both gauges are steady and have the same pressure reading.

11. Conduct a Main Drain Test to make sure the water supply is satisfactory (see Flow Test at Main Drain Valve).

12. Open the Alarm Control Valve.

13. Conduct a test of the alarm devices (see Testing Alarm and Waterflow Alarm Devices).

14. Seal, lock, or otherwise secure the System Control Valve and Alarm Control Valve in an open position (per NFPA 25). The system is now ready for service.

15. If alarms connect to a central station or fire department, notify the signal receiving station that the system has been returned to service.



# GLOBE ALARM CHECK VALVE INSTALLATION AND MAINTENANCE GUIDE

## 3" MODEL H SERIES VERTICAL POSITION / CONSTANT PRESSURE TRIM

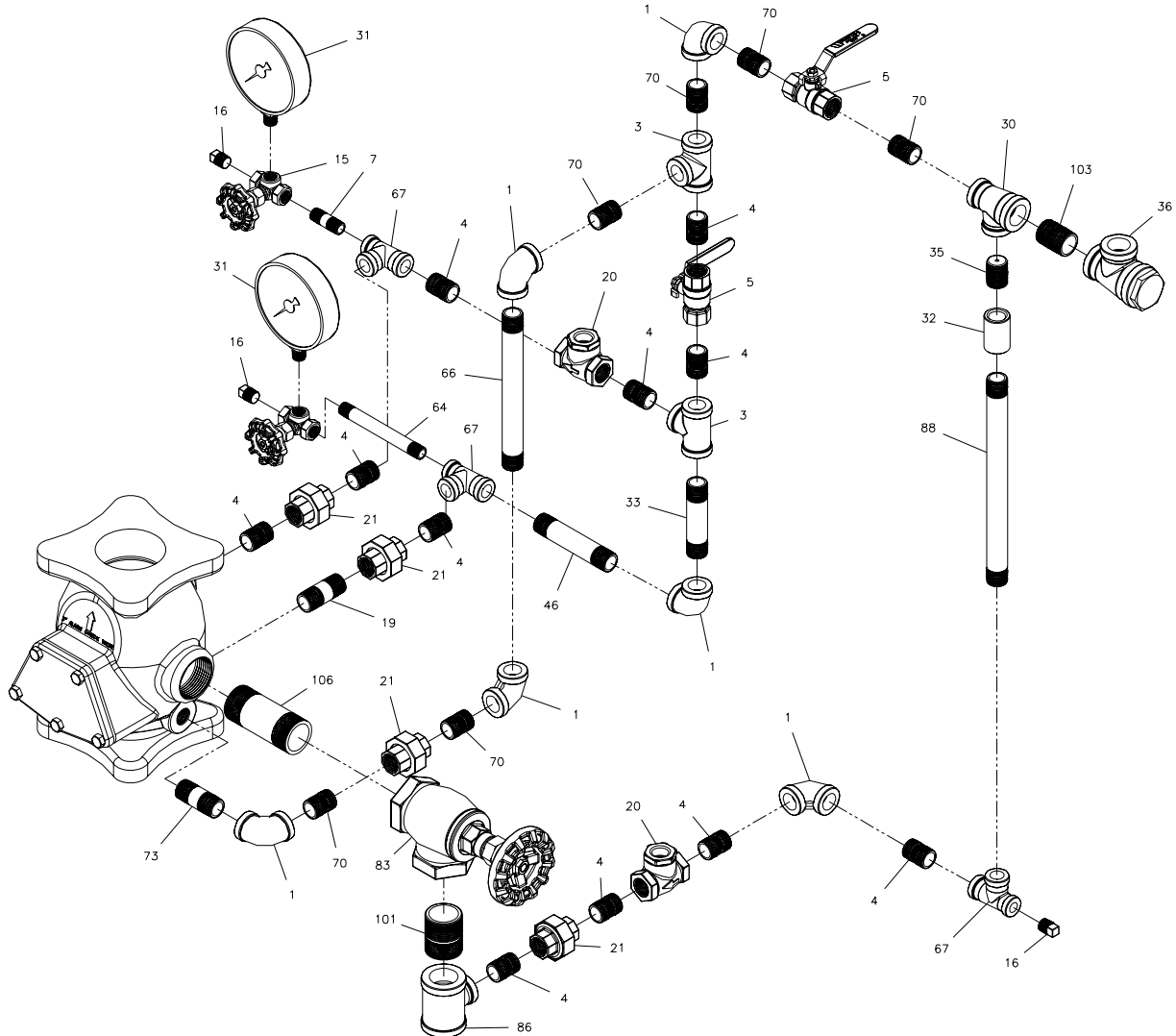

Det. No.	Description	Part No.	Req'd	Det. No.	Description	Part No.	Req'd	Det. No.	Description	Part No.	Req'd
1	1/2" Elbow	311203	6	30	3/4" x 1/2" x 1/2" Tee	311318	1	70	1/2" Close Galv. Nipple	310300-G	6
3	1/2" Tee	311303	2	31	3 1/2" Water Gauge (0-300 psi)	300119	2	73	1/2" x 2" Galv. Nipple	310303-G	1
4	1/2" Close Nipple	310300	11	32	1/2" Coupling	311423	1	83	1 1/2" Angle Valve	311616	1
5	1/2" Ball Valve	311692	2	33	1/2" x 3 1/2" Nipple	310305	1	86	1 1/2" x 1 1/2" x 1/2" Tee	311391	1
7	1/4" x 1 1/2" Nipple	310101	1	35	Alarm Line Bleeder	320506	1	88	1/2" x 10" Nipple	310320	1
15	1/4" 3-Way Valve	311683	2	36	3/4" Strainer	325535	1	101	1 1/2" Close Nipple	310700	1
16	1/4" Plug	311001	3	46	1/2" x 4" Nipple	310306	1	103	3/4" Close Galv. Nipple	310400-G	1
19	1/2" x 2" Nipple	310302	1	64	1/4" x 4" Nipple	310107	1	106	1 1/2" x 3 1/2" Nipple	310704	1
20	1/2" Swing Check Valve	311639	2	66	1/2" x 7 1/2" Nipple	310313	1				
21	1/2" Union	311403	4	67	1/2" x 1/4" x 1/2" Tee	311305	3				

# GLOBE ALARM CHECK VALVE INSTALLATION AND MAINTENANCE GUIDE

## 3" MODEL H SERIES HORIZONTAL POSITION / VARIABLE PRESSURE TRIM

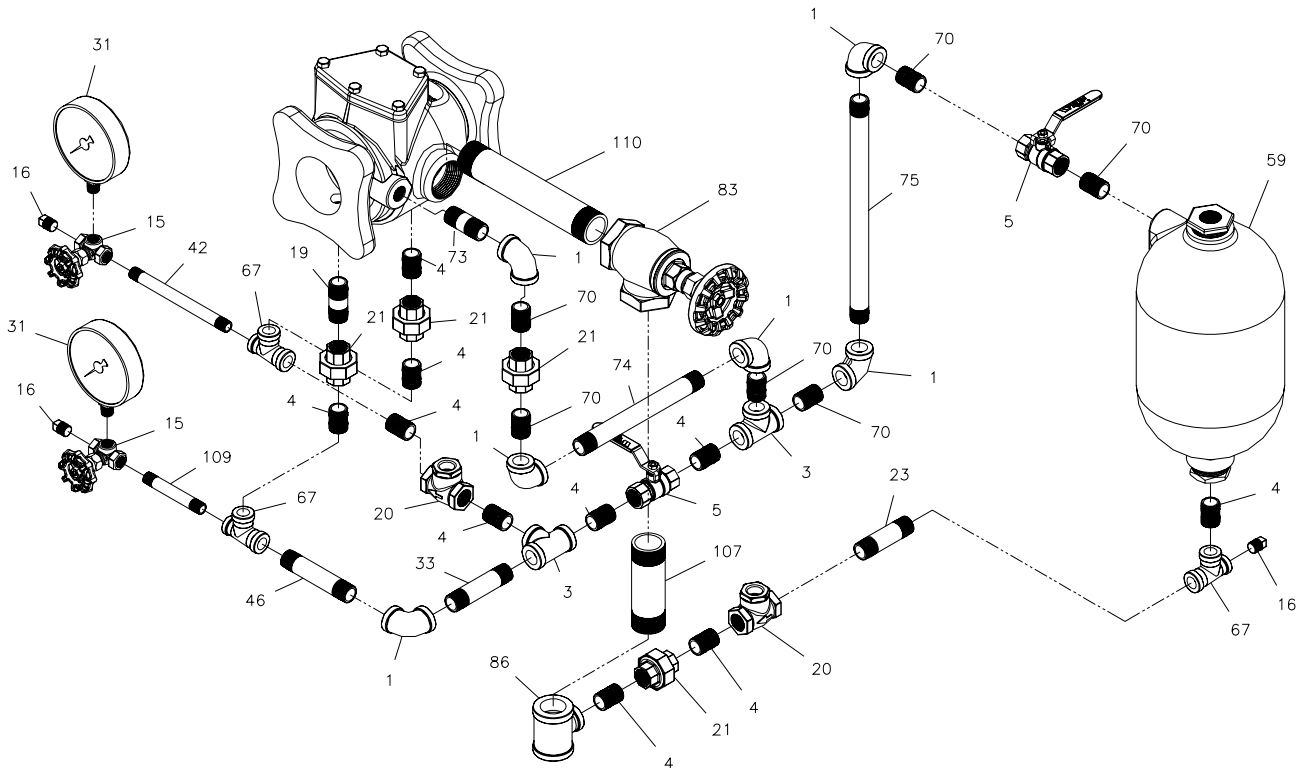

Det. No.	Description	Part No.	Req'd	Det. No.	Description	Part No.	Req'd	Det. No.	Description	Part No.	Req'd
1	1/2" Elbow	311203	6	23	1/2" x 3" Nipple	310304	1	74	1/2" x 7 1/2" Galv. Nipple	310313-G	1
3	1/2" Tee	311303	2	31	3 1/2" Water Gauge (0-300 psi)	300119	2	75	1/2" x 12" Galv. Nipple	310318-G	1
4	1/2" Close Nipple	310300	10	33	1/2" x 3 1/2" Nipple	310305	1	83	1 1/2" Angle Valve	311616	1
5	1/2" Ball Valve	311692	2	42	1/4" x 6" Nipple	310110	1	86	1 1/2" x 1 1/2" x 1/2" Tee	311391	1
15	1/4" 3-Way Valve	311683	2	46	1/2" x 4" Nipple	310306	1	107	1 1/2" x 4 1/2" Nipple	310706	1
16	1/4" Plug	311001	3	59	Retard Chamber	323350	1	109	1/4" x 3 1/2" Nipple	310105	1
19	1/2" x 2" Nipple	310302	1	67	1/2" x 1/4" x 1/2" Tee	311305	3	110	1 1/2" x 8" Nipple	310715	1
20	1/2" Swing Check Valve	311639	2	70	1/2" Close Galv. Nipple	310300-G	6				
21	1/2" Union	311403	4	73	1/2" x 2" Galv. Nipple	310302-G	1				

# GLOBE ALARM CHECK VALVE INSTALLATION AND MAINTENANCE GUIDE

3" MODEL H SERIES HORIZONTAL POSITION / CONSTANT PRESSURE TRIM

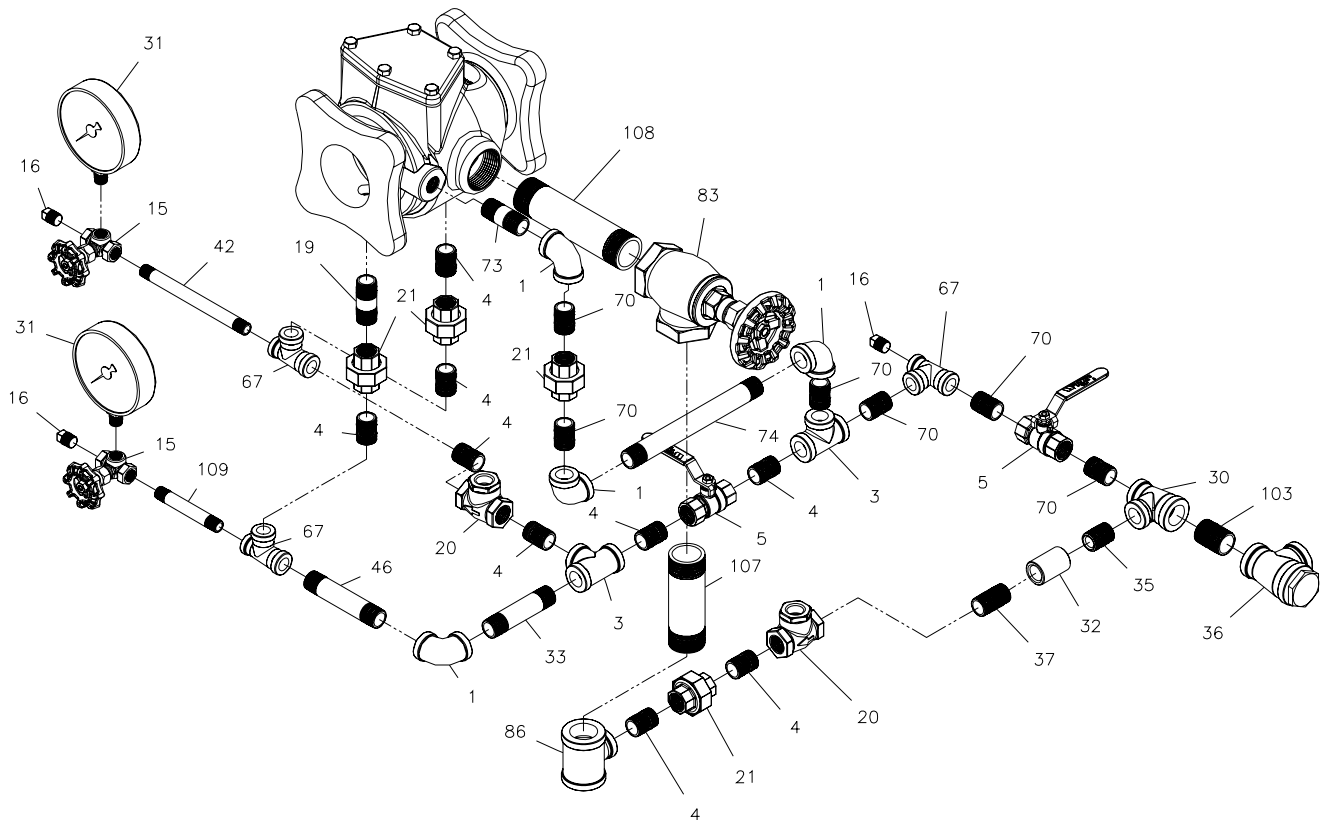

Det. No.	Description	Part No.	Req'd	Det. No.	Description	Part No.	Req'd	Det. No.	Description	Part No.	Req'd
1	1/2" Elbow	311203	4	31	3 1/2" Water Gauge (0-300 psi)	300119	2	73	1/2" x 2" Nipple	310302	1
3	1/2" Tee	311303	2	32	1/2" Coupling	311423	1	74	1/2" x 7 1/2" Galv. Nipple	310313-G	1
4	1/2" Close Nipple	310300	9	33	1/2" x 3 1/2" Nipple	310305	1	83	1 1/2" Angle Valve	311616	1
5	1/2" Ball Valve	311692	2	35	1/2" Alarm Line Bleeder	320506	1	86	1 1/2" x 1 1/2" x 1/2" Tee	311391	1
15	1/4" 3-Way Valve	311683	2	36	3/4" Strainer	325535	1	103	3/4" Close Galv. Nipple	310400-G	1
16	1/4" Plug	311001	3	37	1/2" x 1 1/2" Nipple	310301	1	107	1 1/2" x 4 1/2" Nipple	310706	1
19	1/2" x 2" Nipple	310302	1	42	1/4" x 6" Nipple	310110	1	108	1 1/2" x 6" Nipple	310709	1
20	1/2" Swing Check Valve	311639	2	46	1/2" x 4" Nipple	310306	1	109	1/4" x 3 1/2" Nipple	310105	1
21	1/2" Union	311403	4	67	1/2" x 1/4" x 1/2" Tee	311305	3				
30	3/4" x 3/4" x 1/2" Tee	311318	1	70	1/2" Close Galv. Nipple	310300-G	6				



# GLOBE ALARM CHECK VALVE INSTALLATION AND MAINTENANCE GUIDE

## 4" MODEL H SERIES VERTICAL POSITION / CONSTANT PRESSURE TRIM

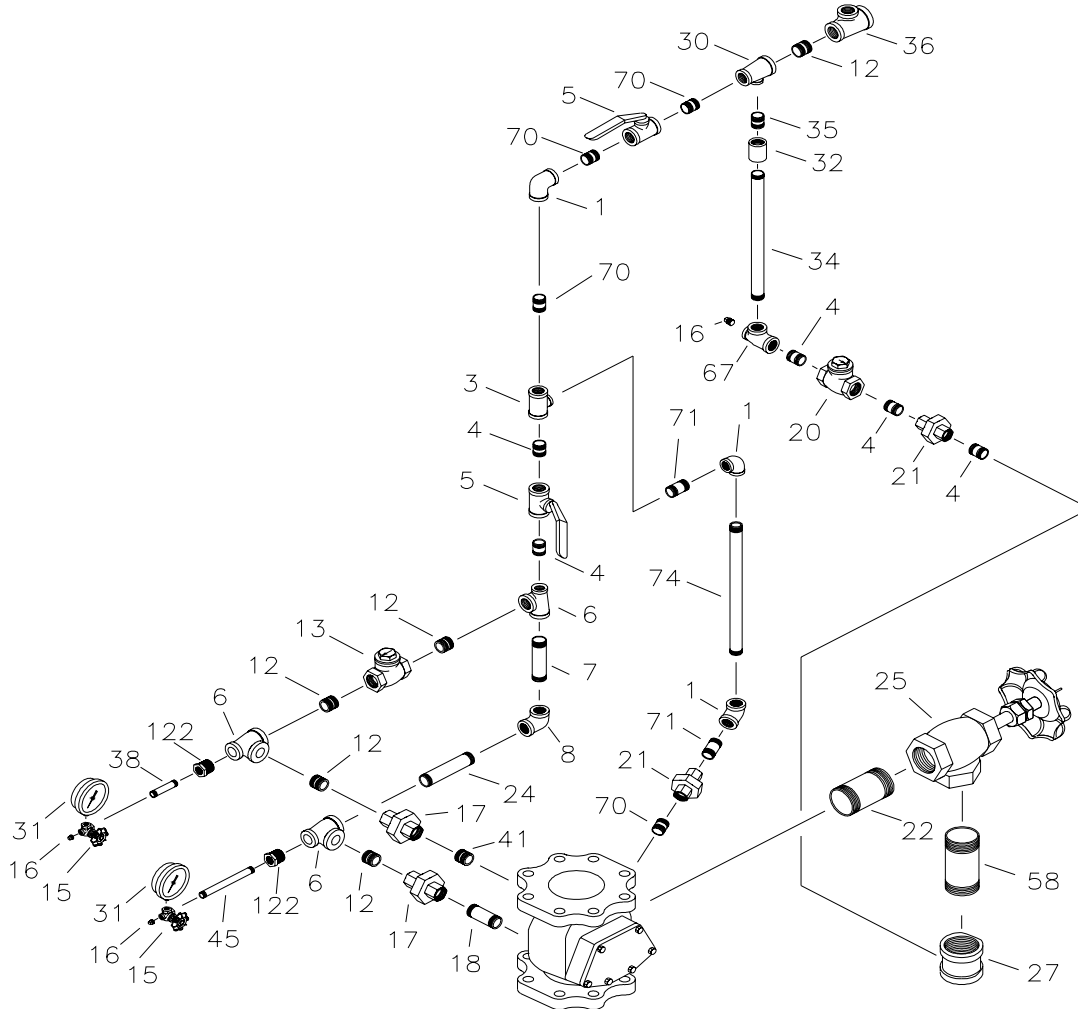

Det. No.	Description	Part No.	Req'd	Det. No.	Description	Part No.	Req'd	Det. No.	Description	Part No.	Req'd
1	1/2" Elbow	311203	3	18	3/4" x 2 1/2" Nipple	310402	1	36	3/4" Strainer	325535	1
3	1/2" Tee	311303	1	20	1/2" Swing Check Valve	311639	1	37	1/2" x 1 1/2" Nipple	310301	2
4	1/2" Close Nipple	310300	3	21	1/2" Union	311403	2	38	1/4" x 2" Nipple	310102	1
5	1/2" Ball Valve	311692	2	22	2" x 3" Nipple	310802	1	41	3/4" x 1 1/2" Nipple	310413	1
6	3/4" x 1/2" x 3/4" Tee	311313	3	24	3/4" x 4 1/2" Nipple	310406	1	45	1/4" x 5" Nipple	310108	1
7	3/4" x 3" Nipple	310403	1	25	2" Angle Valve	311617	1	58	2" x 2 1/2" Nipple	310801	1
8	3/4" Elbow	311204	1	27	2" x 2" x 1/2" Tee	311380	1	67	1/2" X 1/4" X 1/2" Tee	311305	1
12	3/4" Close Nipple	310400	5	30	3/4" x 1/2" x 1/2" Tee	311318	1	70	1/2" Close Galv. Nipple	310300-G	4
13	3/4" Swing Check Valve	311640	1	31	3 1/2" Water Gauge (0-300 psi)	300119	2	71	1/2" x 1 1/2" Galv. Nipple	310301-G	2
15	1/4" 3-Way Valve	311683	2	32	1/2" Coupling	311423	1	74	1/2" x 8 1/2" Galv. Nipple	310316-G	1
16	1/4" Plug	311001	3	34	1/2" x 12" Nipple	310318	1	122	1/2" x 1/4" Reducing Bushing	311100	2
17	3/4" Union	311404	2	35	Alarm Line Bleeder	320506	1				

# GLOBE ALARM CHECK VALVE INSTALLATION AND MAINTENANCE GUIDE

## 4" MODEL H SERIES HORIZONTAL POSITION / VARIABLE PRESSURE TRIM

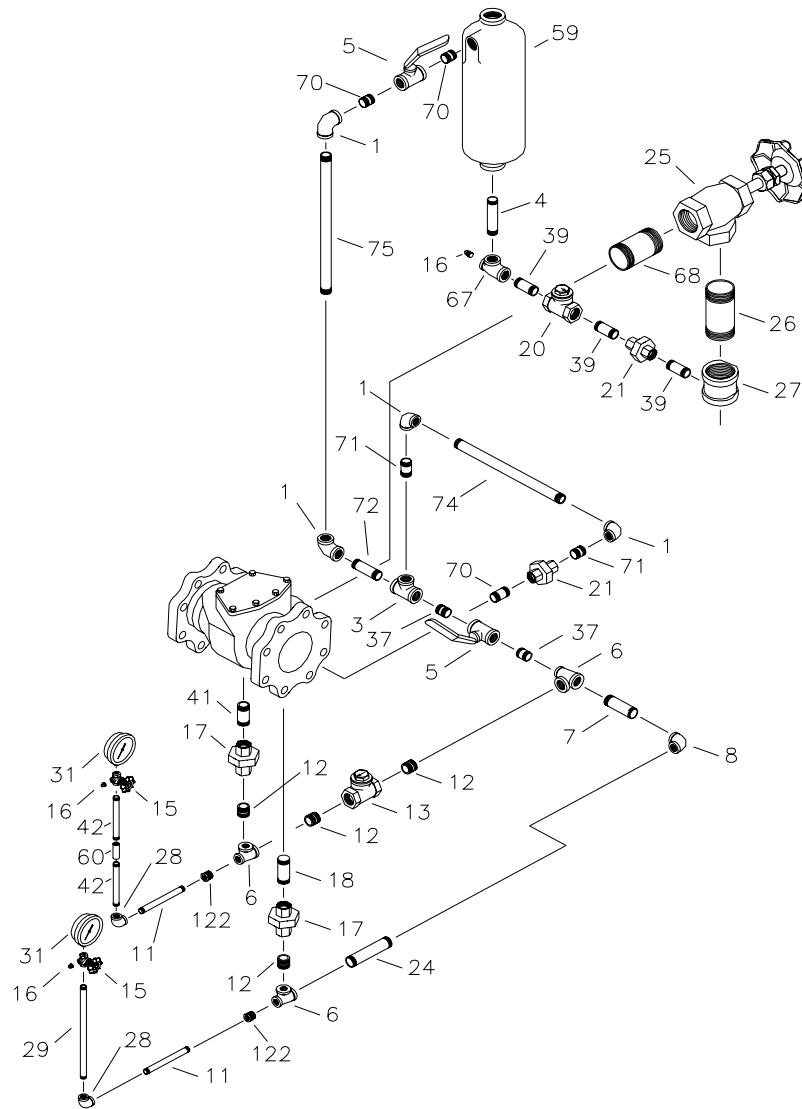

Det. No.	Description	Part No.	Req'd	Det. No.	Description	Part No.	Req'd	Det. No.	Description	Part No.	Req'd
1	1/2" Elbow	311203	4	18	3/4" x 2 1/2" Nipple	310402	1	42	1/4" x 6" Nipple	310110	2
3	1/2" Tee	311303	1	20	1/2" Swing Check Valve	311639	1	59	Retard Chamber	323350	1
4	1/2" Close Nipple	310300	1	21	1/2" Union	311403	2	60	1/4" Coupling	311402	1
5	1/2" Ball Valve	311692	2	24	3/4" x 4 1/2" Nipple	310406	1	67	1/2" x 1/4" x 1/2" Tee	311305	1
6	3/4" x 1/2" x 3/4" Tee	311313	3	25	2" Angle Valve	311617	1	68	2" x 7 1/2" Nipple	310809	1
7	3/4" x 3" Nipple	310403	1	26	2" x 5" Nipple	310803	1	70	1/2" Close Galv. Nipple	310300-G	3
8	3/4" Elbow	311204	1	27	2" x 2" x 1/2" Tee	311380	1	71	1/2" x 1 1/2" Galv. Nipple	310301-G	2
11	1/4" x 6 1/2" Nipple	310115	2	28	1/4" Elbow	311201	2	72	1/2" x 2 1/2" Galv. Nipple	310303-G	1
12	3/4" Close Nipple	310400	4	29	1/4" x 10" Nipple	310136	1	74	1/2" x 8 1/2" Galv. Nipple	310316-G	1
13	3/4" Swing Check Valve	311640	1	31	3 1/2" Water Gauge (0-300 psi)	300119	2	75	1/2" x 12" Galv. Nipple	310318-G	1
15	1/4" 3-Way Valve	311683	2	37	1/2" x 1 1/2" Nipple	310301	2	122	1/2" x 1/4" Reducing Bushing	311100	2
16	1/4" Plug	311001	3	39	1/2" x 2 1/2" Nipple	310303	3				
17	3/4" Union	311404	2	41	3/4" x 1 1/2" Nipple	310413	1				

# GLOBE ALARM CHECK VALVE INSTALLATION AND MAINTENANCE GUIDE

## 4" MODEL H SERIES HORIZONTAL POSITION / CONSTANT PRESSURE TRIM

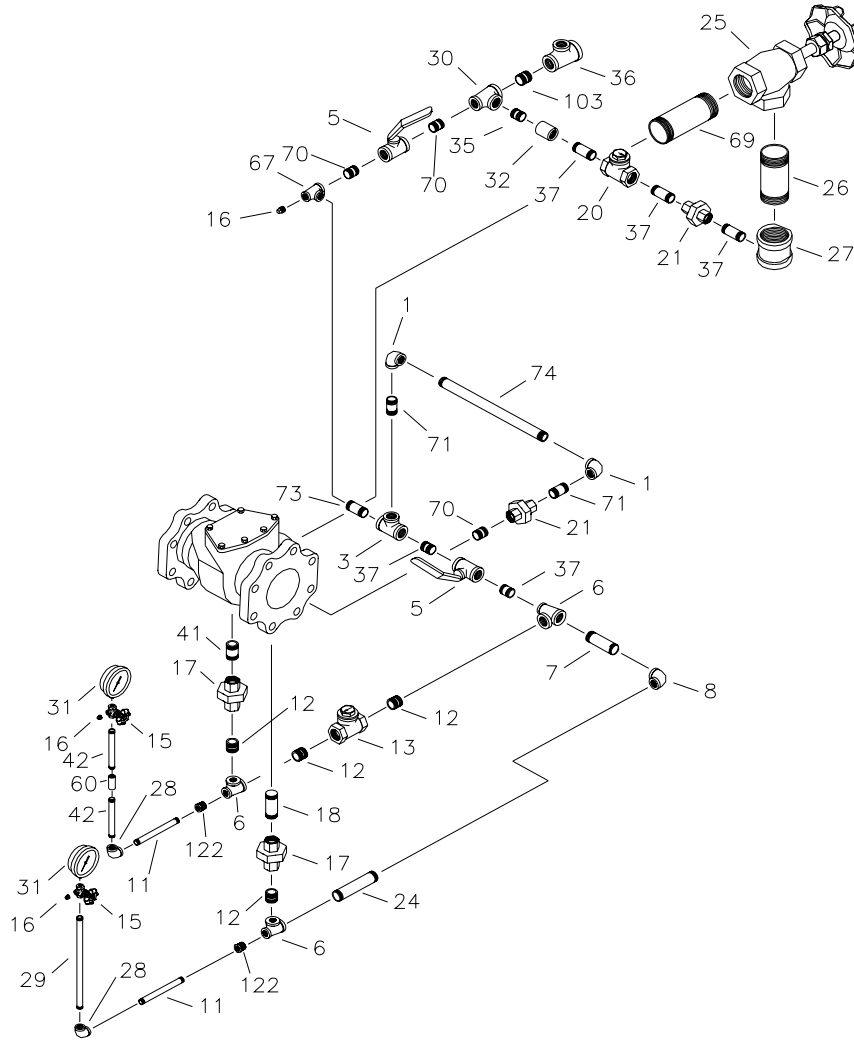

Det. No.	Description	Part No.	Req'd	Det. No.	Description	Part No.	Req'd	Det. No.	Description	Part No.	Req'd
1	1/2" Elbow	311203	2	20	1/2" Swing Check Valve	311639	1	37	1/2" x 1 1/2" Nipple	310301	5
3	1/2" Tee	311303	1	21	1/2" Union	311403	2	41	3/4" x 1 1/2" Nipple	310413	1
5	1/2" Ball Valve	311692	2	24	3/4" x 4 1/2" Nipple	310406	1	42	1/4" x 6" Nipple	310110	2
6	3/4" x 1/2" x 3/4" Tee	311313	3	25	2" Angle Valve	311617	1	60	1/4" Coupling	311402	1
7	3/4" x 3" Nipple	310403	1	26	2" x 5" Nipple	310803	1	67	1/2" x 1/4" x 1/2" Tee	311305	1
8	3/4" Elbow	311204	1	27	2" x 2" x 1/2" Tee	311380	1	69	2" x 6" Nipple	310808	1
11	1/4" x 6 1/2" Nipple	310115	2	28	1/4" Elbow	311201	2	70	1/2" Close Galv. Nipple	310300-G	3
12	3/4" Close Nipple	310400	4	29	1/4" x 10" Nipple	310136	1	71	1/2" x 1 1/2" Galv. Nipple	310301-G	2
13	3/4" Swing Check Valve	311640	1	30	3/4" x 1/2" x 1/2" Tee	311318	1	73	1/2" x 2" Galv. Nipple	310302-G	1
15	1/4" 3-Way Valve	311683	2	31	3 1/2" Water Gauge (0-300 psi)	300119	2	74	1/2" x 8 1/2" Galv. Nipple	310316-G	1
16	1/4" Plug	311001	3	32	1/2" Coupling	311423	1	103	3/4" Close Galv. Nipple	310400-G	1
17	3/4" Union	311404	2	35	Alarm Line Bleeder	320506	1	122	1/2" x 1/4" Reducing Bushing	311100	2
18	3/4" x 2 1/2" Nipple	310402	1	36	3/4" Strainer	325535	1				

# GLOBE ALARM CHECK VALVE INSTALLATION AND MAINTENANCE GUIDE

## 6" MODEL H SERIES VERTICAL POSITION / VARIABLE PRESSURE TRIM

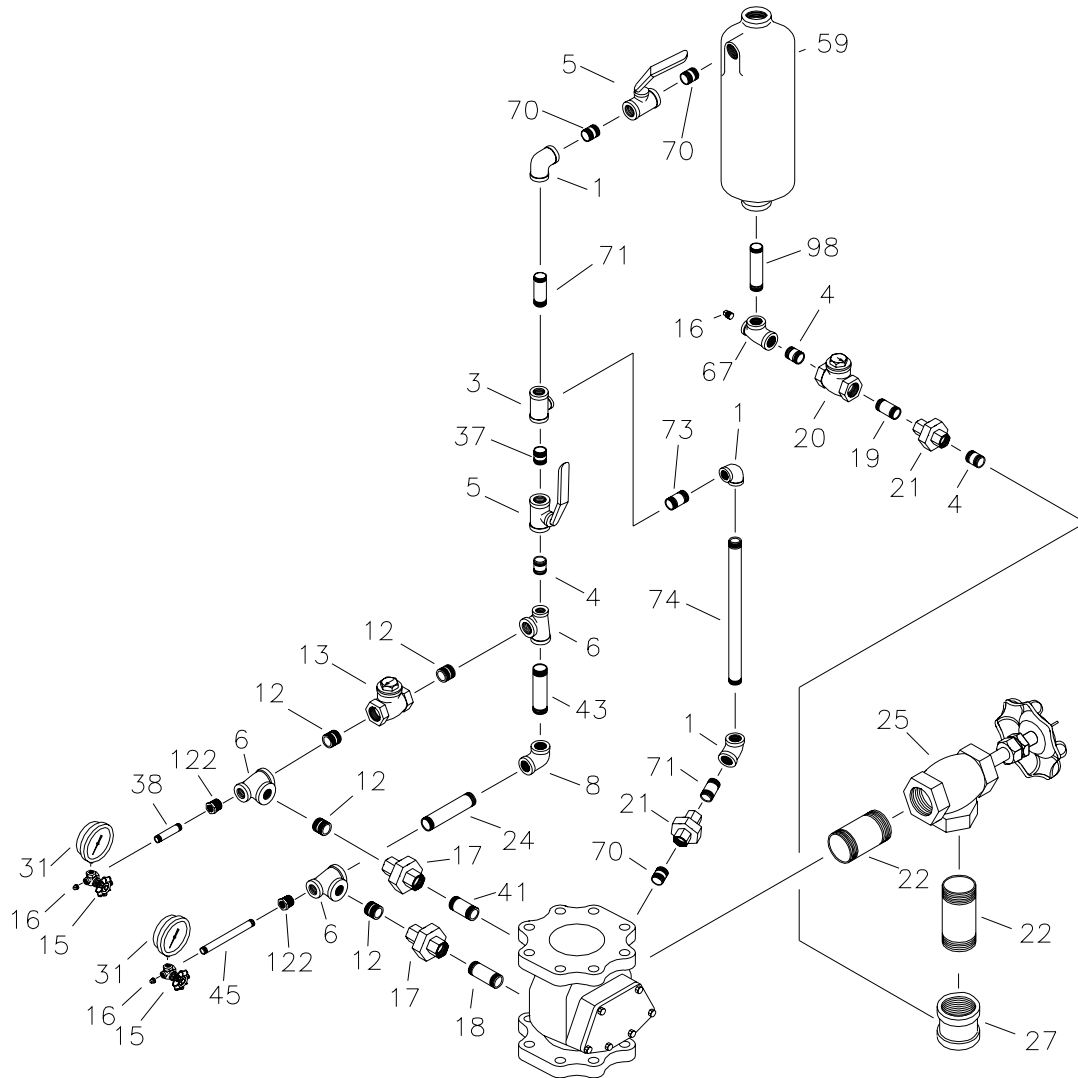

Det. No.	Description	Part No.	Req'd	Det. No.	Description	Part No.	Req'd	Det. No.	Description	Part No.	Req'd
1	1/2" Elbow	311203	3	18	3/4" x 2 1/2" Nipple	310402	1	41	3/4" x 1 1/2" Nipple	310413	1
3	1/2" Tee	311303	1	19	1/2" x 2" Nipple	310302	1	43	3/4" x 3 1/2" Nipple	310404	1
4	1/2" Close Nipple	310300	3	20	1/2" Swing Check Valve	311639	1	45	1/4" x 5" Nipple	310108	1
5	1/2" Ball Valve	311692	2	21	1/2" Union	311403	2	59	Retard Chamber	323350	1
6	3/4" x 1/2" x 3/4" Tee	311313	3	22	2" x 3" Nipple	310802	2	67	1/2" x 1/4" x 1/2" Tee	311305	1
8	3/4" Elbow	311204	1	24	3/4" x 4 1/2" Nipple	310406	1	70	1/2" Close Galv. Nipple	310300-G	3
12	3/4" Close Nipple	310400	4	25	2" Angle Valve	311617	1	71	1/2" x 1 1/2" Galv. Nipple	310301-G	2
13	3/4" Swing Check Valve	311640	1	27	2" x 2" x 1/2" Tee	311380	1	73	1/2" x 2" Galv. Nipple	310302-G	1
15	1/4" 3-Way Valve	311683	2	31	3 1/2" Water Gauge (0-300 psi)	300119	2	74	1/2" x 8 1/2" Galv. Nipple	310316-G	1
16	1/4" Plug	311001	3	37	1/2" x 1 1/2" Nipple	310301	1	98	1/2" x 4 1/2" Nipple	310307	1
17	3/4" Union	311404	2	38	1/4" x 2" Nipple	310102	1	122	1/2" x 1/4" Reducing Bushing	311100	2

# GLOBE ALARM CHECK VALVE INSTALLATION AND MAINTENANCE GUIDE

## 6" MODEL H SERIES VERTICAL POSITION / CONSTANT PRESSURE TRIM

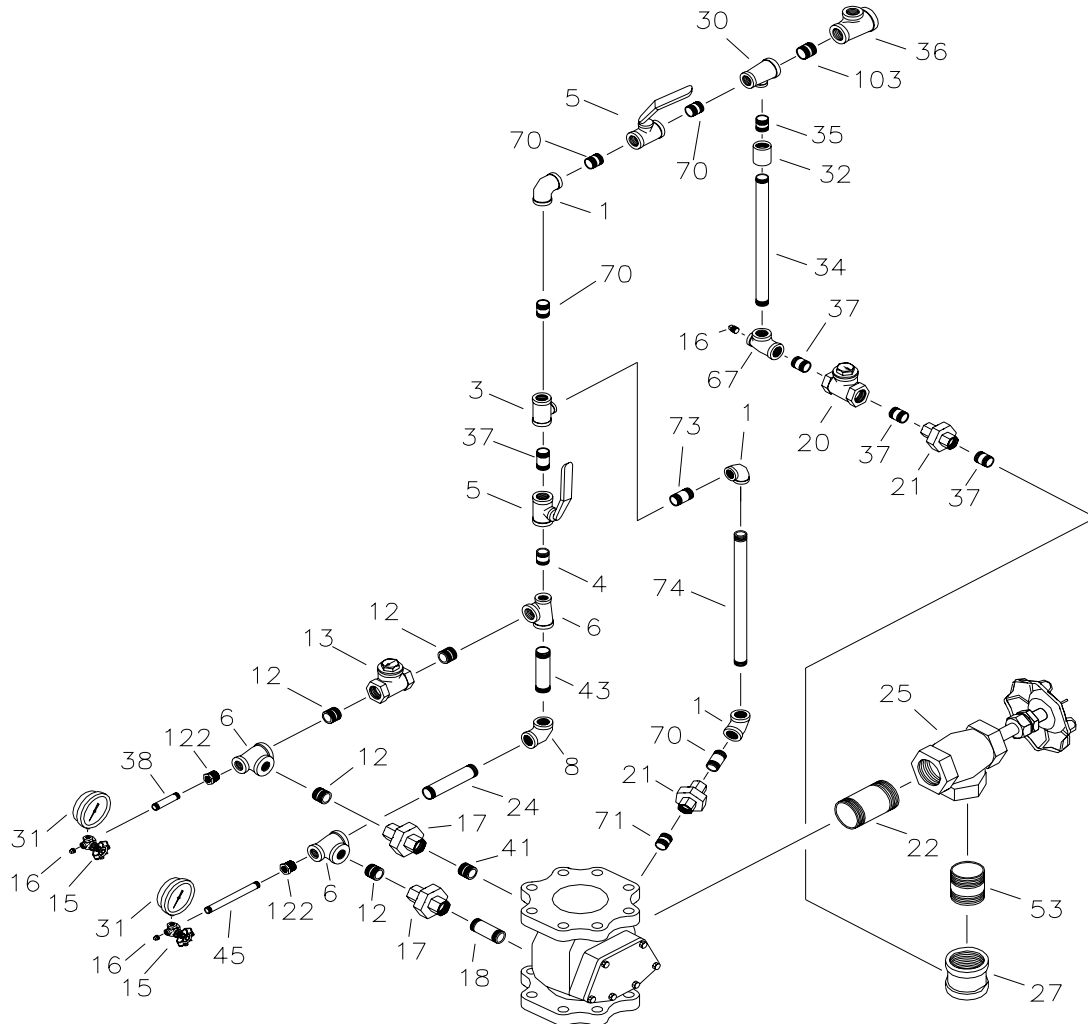

Det. No.	Description	Part No.	Req'd	Det. No.	Description	Part No.	Req'd	Det. No.	Description	Part No.	Req'd
1	1/2" Elbow	311203	3	21	1/2" Union	311403	2	41	3/4" x 1 1/2" Niple	310413	1
3	1/2" Tee	310309	1	22	2" x 3" Nipple	310802	1	43	3/4" x 3 1/2" Nipple	310404	1
4	1/2" Close Nipple	310300	1	24	3/4" x 4 1/2" Nipple	310406	1	45	1/4" x 5" Nipple	310108	1
5	1/2" Ball Valve	311692	2	25	2" Angle Valve	311617	1	53	2" Close Nipple	310800	1
6	3/4" x 1/2" x 3/4" Tee	311313	3	27	2" x 2" x 1/2" Tee	311380	1	67	1/2" x 1/4" x 1/2" Tee	311305	1
8	3/4" Elbow	311204	1	30	3/4" x 1/2" x 1/2" Tee	311318	1	70	1/2" Close Galv. Nipple	310300-G	4
12	3/4" Close Nipple	310400	4	31	3 1/2" Water Gauge (0-300 psi)	300119	2	71	1/2" x 1 1/2" Galv. Nipple	310301-G	1
13	3/4" Swing Check Valve	311640	1	32	1/2" Coupling	311423	1	73	1/2" x 2" Galv. Nipple	310302-G	1
15	1/4" 3-Way Valve	311683	2	34	1/2" x 12" Nipple	310318	1	74	1/2" x 8 1/2" Galv. Nipple	310316-G	1
16	1/4" Plug	311001	3	35	Alarm Line Bleeder	320506	1	103	3/4" Close Galv. Nipple	310400-G	1
17	3/4" Union	311404	2	36	3/4" Strainer	325535	1	122	1/2" x 1/4" Reducing Bushing	311100	2
18	3/4" x 2 1/2" Nipple	310402	1	37	1/2" x 1 1/2" Nipple	310301	4				
20	1/2" Swing Check Valve	311639	1	38	1/4" x 2" Nipple	310102	1				

# GLOBE ALARM CHECK VALVE INSTALLATION AND MAINTENANCE GUIDE

## 6" MODEL H SERIES HORIZONTAL POSITION / VARIABLE PRESSURE TRIM

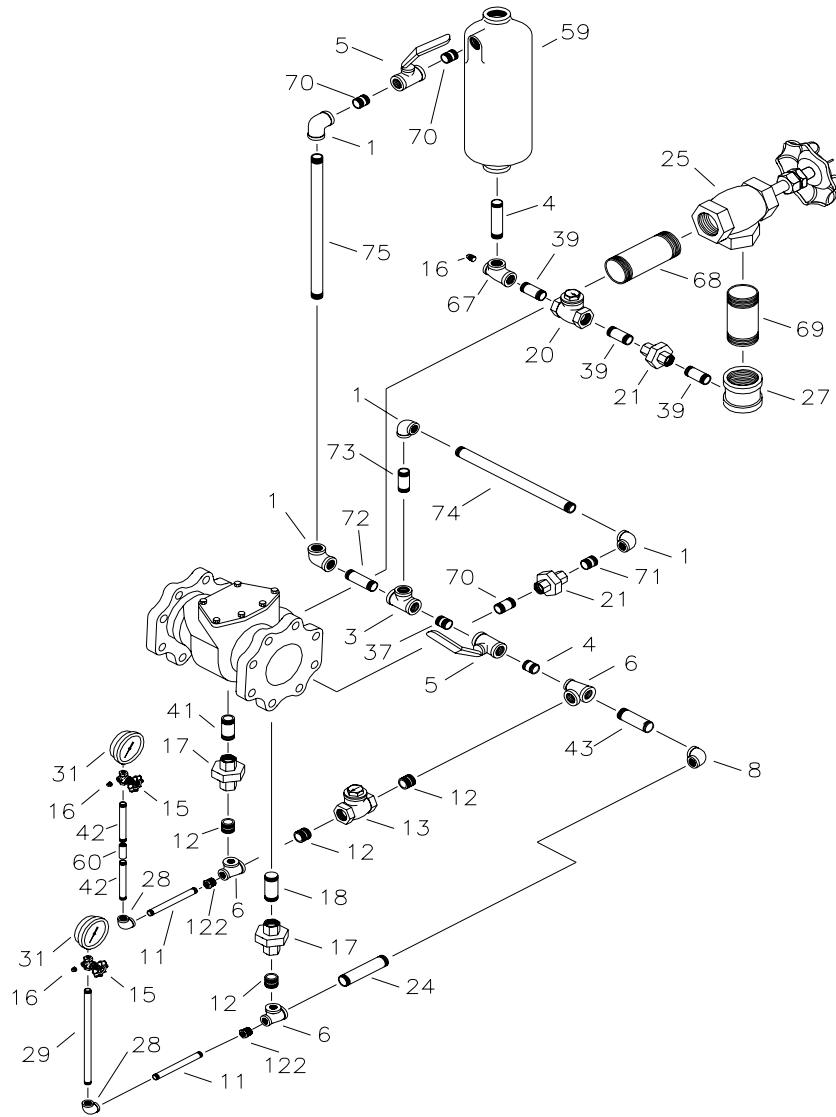

Det. No.	Description	Part No.	Req'd	Det. No.	Description	Part No.	Req'd	Det. No.	Description	Part No.	Req'd
1	1/2" Elbow	311203	4	20	1/2" Swing Check Valve	311639	1	59	Retard Chamber	323350	1
3	1/2" Tee	311303	1	21	1/2" Union	311403	2	60	1/4" Coupling	311402	1
4	1/2" Close Nipple	310300	2	24	3/4" x 4 1/2" Nipple	310406	1	67	1/2" x 1/4" x 1/2" Tee	311305	1
5	1/2" Ball Valve	311692	2	25	2" Angle Valve	311617	1	68	2" x 7 1/2" Nipple	310809	1
6	3/4" x 1/2" x 3/4" Tee	311313	3	27	2" x 2" x 1/2" Tee	311380	1	69	2" x 6" Nipple	310808	1
8	3/4" Elbow	311204	1	28	1/4" Elbow	311201	2	70	1/2" Close Galv. Nipple	310300-G	3
11	1/4" x 6 1/2" Nipple	310115	2	29	1/4" x 10" Nipple	310136	1	71	1/2" x 1 1/2" Galv. Nipple	310301-G	1
12	3/4" x Close Nipple	310400	4	31	3 1/2" Water Gauge (0-300 psi)	300119	2	72	1/2" x 2 1/2" Galv. Nipple	310303-G	1
13	3/4" Swing Check Valve	311640	1	37	1/2" x 1 1/2" Nipple	310301	1	73	1/2" x 2" Galv. Nipple	310302-G	1
15	1/4" 3-Way Valve	311683	2	39	1/2" x 2 1/2" Nipple	310303	3	74	1/2" x 8 1/2" Galv. Nipple	310316-G	1
16	1/4" Plug	311001	3	41	3/4" x 1 1/2" Nipple	310413	1	75	1/2" x 12" Galv. Nipple	310318-G	1
17	3/4" Union	311404	2	42	1/4" x 6" Nipple	310110	2	122	1/2" x 1/4" Reducing Bushing	311100	2
18	3/4" x 2 1/2" Nipple	310402	1	43	3/4" x 3 1/2" Nipple	310404	1				

# GLOBE ALARM CHECK VALVE INSTALLATION AND MAINTENANCE GUIDE

6" MODEL H SERIES HORIZONTAL POSITION / CONSTANT PRESSURE TRIM

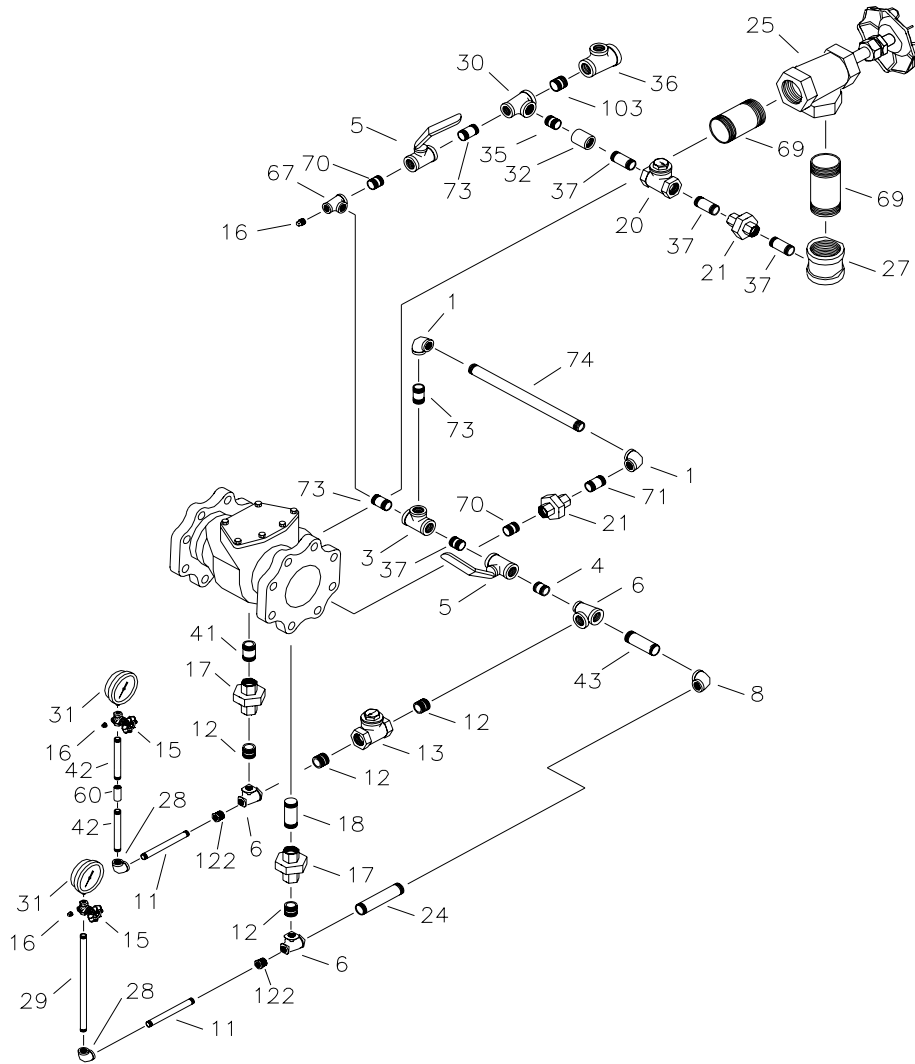

Det. No.	Description	Part No.	Req'd	Det. No.	Description	Part No.	Req'd	Det. No.	Description	Part No.	Req'd
1	1/2" Elbow	311203	2	20	1/2" Swing Check Valve	311639	1	41	3/4" x 1 1/2" Nipple	310413	1
3	1/2" Tee	311303	1	21	1/2" Union	311403	2	42	1/4" x 6" Nipple	310110	2
4	1/2" Close Nipple	310300	1	24	3/4" x 4 1/2" Nipple	310406	1	43	3/4" X 3 1/2" Nipple	310404	1
5	1/2" Ball Valve	311692	2	25	2" Angle Valve	311617	1	60	1/4" Coupling	311402	1
6	3/4" x 1/2" x 3/4" Tee	311313	3	27	2" x 2" x 1/2" Tee	311380	1	67	1/2" x 1/4" x 1/2" Tee	311305	1
8	3/4" Elbow	311204	1	28	1/4" Elbow	311201	2	69	2" x 6" Nipple	310808	2
11	1/4" x 6 1/2" Nipple	310115	2	29	1/4" x 10" Nipple	310136	1	70	1/2 Close Galv. Nipple	310300-G	2
12	3/4" Close Nipple	310400	4	30	3/4" x 1/2" x 1/2" Tee	311318	1	71	1/2" x 1 1/2" Galv. Nipple	310301-G	1
13	3/4" Swing Check Valve	311640	1	31	3 1/2" Water Gauge (0-300 psi)	300119	2	73	1/2" x 2" Galv. Nipple	310302-G	3
15	1/4" 3-Way Valve	311683	2	32	1/2" Coupling	311423	1	74	1/2" x 8 1/2" Galv. Nipple	310316-G	1
16	1/4" Plug	311001	3	35	Alarm Line Bleeder	320506	1	103	3/4" Close Galv. Nipple	310400-G	1
17	3/4" Union	311404	2	36	3/4" Strainer	325535	1	122	1/2" x 1/4" Reducing Bushing	311100	2
18	3/4" x 2 1/2" Nipple	310402	1	37	1/2" x 1 1/2" Nipple	310301	4				





# GLOBE ALARM CHECK VALVE INSTALLATION AND MAINTENANCE GUIDE

## OPTIONAL ALARM PRESSURE SWITCH TRIM

FOR USE WHEN SWITCH IS PROVIDED WITH MECHANICAL ALARM.

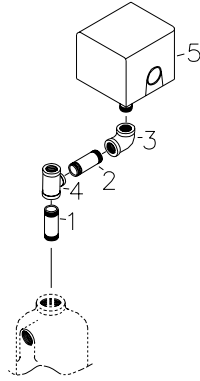

FOR USE WHEN SWITCH IS PROVIDED WITHOUT MECHANICAL ALARM, TO PREVENT AIR LOCKS.

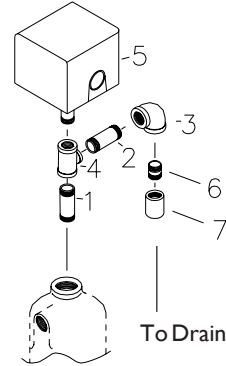

Det. No.	Description	Part No.	Req'd
1	3/4" x 4 1/2" Nipple	310406	1
2	1/2" x 4" Nipple	310306	1
3	1/2" Elbow	311203	1
4	3/4" x 3/4" x 1/2" Tee	311317	1
5	Pressure Switch*	301650	1

Det. No.	Description	Part No.	Req'd
1	3/4" x 4 1/2" Nipple	310406	1
2	1/2" x 4" Nipple	310306	1
3	1/2" Elbow	311203	1
4	3/4" x 1/2" x 1/2" Tee	311318	1
5	Pressure Switch*	301650	1
6	Alarm Line Bleeder	320506	1
7	1/2" Coupling	311423	1

\*NOTE: Other pressure switches available upon request. May be substituted depending on application.

## PRESSURE RELIEF VALVE FOR USE IN GRIDDED SYSTEMS

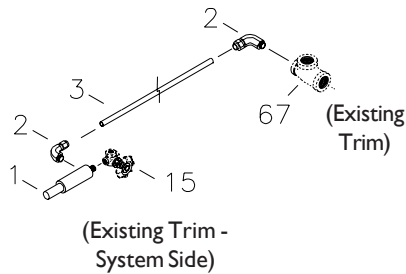

## MODEL H VALVES

Det. No.	Description	Part No.	Req'd
1	1/4" Pressure Relief Valve	323640	1
2	1/4" NPT Male x 1/4" Tube Elbow	320603	2
3	1/4" Copper Tubing	M-320604	2'