

Power Threader BT-5020 Owner's Manual



WARNING!

Read this owner's manual before assembling and operating the unit. The moving parts of this unit may cause body injury if it is not proper operated. Always unplug the Power Cord and switch the main switch to off position before maintenance or service.

Berkley Tool, Jupiter, Florida, USA

Table of Contents

1. GENERAL SAFETY RULES	1
2. SPECIFICATION	3
3. FUNCTION/OPERATION DESCRIPTION	3
3.1 Using BT-30033 pipe cutter	3
3.2 Using BT-30032 reamer	3
3.3 Using BT-99992 quick-opening die head	4
3.4 Using BT-30033 pipe cutter	4
3.5 Assembly	5
3.6 Locking the Footswitch	5
4. MAINTENANCE	6
5. ACCESSORIES	6
6. Power Threader Exploded View & Parts List	7
7. BT-31043 Power Threader Motor Assembly Exploded View & Parts List	8
8. REGISTRATION FORM	9
9. LIMITED WARRANTY	9

SAVE THESE INSTRUCTIONS

1. GENERAL SAFETY RULES

WARNING! Read and understand all instructions. Failure to follow all instructions listed below may result in electric shock, fire and/or serious personal injury.

Work Area

Keep your work area clean and well lit. Cluttered benches and dark areas invite accidents.

Do not operate power tools in explosive atmospheres, such as in the presence of flammable liquids, gases, or dust. Power tools create sparks that may ignite the dust or fumes.

Keep children away. All visitors should be kept at a safe distance from work area.

Electrical Safety

This tool is intended for use on a circuit that has an outlet that looks like the one illustrated in the sketch. The tool has a grounding plug that looks like the plug illustrated in the sketch. Grounded tools must be plugged into an outlet properly installed and grounded in accordance with all codes and ordinances. Never remove the grounding prong or modify the plug in any way. Do not use any adapter. Check with a qualified electrician if you are in doubt as to whether the outlet is properly grounded. If the tools should electrically malfunction or break down, grounding provides a low resistance path to carry away from the user. Improper connection of the equipment-grounding conductor can result in a risk of electric shock. The conductor with insulation having an outer surface that is green with or without yellow stripes is the equipment-grounding conductor. If repair or replacement of the electric cord or plug is necessary, do not connect the equipment-grounding conductor to a live terminal.

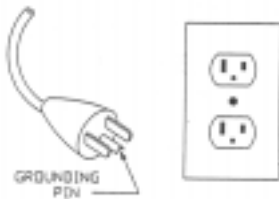

Safety Instructions

Due to the nature of the machine, safety rule and proper procedure must be followed. Otherwise, the high torque of the motor, moving parts and electricity could cause body injury and property damage.

- Ground machine. Use approved three-conductor cord and three-prong ground type plug in a grounded receptacle.
- Use only three-wire extension cords, which have three-prong grounding plugs, and three-pole receptacles that accept the machine's plug. Replace or repair damage, frayed, broken or worn cords.
- Use Proper Extension Cord. Make sure your extension cord is in good condition. When using an extension cord, be sure to use one heavy enough to carry the current your product will draw. An undersized cord will cause a drop in line voltage resulting in loss of power and overheating. The following table shows the correct size to use depending on cord length and nameplate ampere rating. If in doubt, use the next heavier gage. The smaller the gage number, the heavier the cord.

LENGTH OF CORD	WIRE GAGE REQUIRED (120V)
24 FEET	14
50 FEET	12
100 FEET	10
150 FEET	8
200 FEET	6

The machine is made to thread and cut pipe or bolt. Follow instructions in operator's manual on machine uses. Other uses may cause injury.

- Secure machine to bench or stand to keep it from tipping over.
- Tighten chuck hand wheel and engage rear-centering device on the work before turning on machine.
- Support long, heavy work with a pipe support to prevent tipping of machine.
- Use recommended accessories. Use of other accessories may increase the risk of injury. Refer to operator's manual for recommended accessories.
- Do not use machine if switches are broken.
- Always use footswitch. Do not block or disconnect the footswitch
- No loose clothes, ties or gloves. Keep sleeves and jacket buttoned.
- Non slip footwear is recommended. Wear protective hair covering to contain long hair.
- Do not over reach. Keep proper footing & balance at all times.
- Operate machine from switch side only. Do not cross over the machine.
- Always set switch to "OFF" position while machine is not being used.
- Make sure switch is on "OFF" position before plugging the power cord in.
- Unplug the power cord when adjusting, servicing or changing accessories.
- Make sure the machine properly grounded. Please note that the machine is designed to operate at 120 V and 50-60 Hz.
- Use only three-wire extension cord when it is needed. Refer to the chart for correct gauge.
- For personal safety protection, wear eye safety glasses and ear protection all the time.
- Do not use machine in damp or wet locations. Do not expose to rain.
- Use a pipe stand to support the heavy or long pipe while working with it.
- Maintain Tools With Care. Keep tools sharp and clean for best and safest performance. Follow instructions for lubricating and changing accessories.
- Never Stand on Tool. Serious injury could occur if he tool is tipped or if the cutting tool is unintentionally contacted.
- Check for Damaged Parts. Before further use of the tool, a guard or other part that is damaged should be carefully checked to determine that it will operate properly and perform its intended function – check for alignment of moving parts, binding of moving parts, breakage of parts, mounting, and any other conditions that may affect its operation. A guard or other part that is damaged should be properly repaired or replaced.
- Never Leave Tool Running Unattended. Turn Power Off. Do not leave tool until it comes to a complete stop.

2. Specifications

Capacity

Threading

Pipe.....	1/8" to 2"
Bolt.....	1/4" to 2"

Cutoff

Pipe.....	1/8" to 2"
Bolt.....	1/4" to 1"

Power Supply

Volt.....	120v 50-60 Hz single phase AC
Motor.....	1/2 HP
Weight (machine only).....	80 lbs.

3. Function/Operation Description

3.1 Using BT-30033 pipe cutter

- Swing die head and reamer away to out-of-way position.
- Lower pipe cutter down to pipe.
- Move carriage to adjust cutter wheel position to where the pipe will be cut.
- Tighten the pipe cutter handle and make sure the two rollers and cutter wheel touch the pipe
- Turn switch to "forward" position and step on the foot switch.
- Keep turning the pipe cutter handle until pipe is cut off.
- Release footswitch and switch it OFF position.
- Return pipe cutter to out-of-way position.

3.2 Using BT-30032 reamer

- Swing pipe cutter and die head to out-of-way position
- Lower reamer (BT-30032) and align with pipe
- Extend reamer by pushing Latch and sliding knob toward pipe until latch engages square bar
- Switch to forward position and step on foot switch.
- Moving carriage toward to pipe and complete reaming the pipe
- Retract reamer bar ad return reamer to out-of-way position.

3.3 Using BT-99992 quick-opening die head

BT-99992 quick-opening die head is designed to thread 1/8" to 2" NPT. Choose right die first to make correct thread.

Install or replace die

- Lay die head on table or bench with numbers face up.
- Flip throw out lever to OPEN position
- Loosen clamp lever enough to lift clamp lever washer up out of slot.
- Lift tongue of clamp lever washer up out of slot under scale plate. Slide throw out lever all the way to end of slot in the over direction indicated on scale plate.
- Remove dies from die head (if replacing die)
- Insert dies to mark on the side of dies. Make sure the number on the die and cover match up.
- Slide throw out lever back to let clamp lever washer drop in slot under size bar.
- Adjust die head to align index line with right size and tighten down the clamp lever
- Put die head back to carriage and it's ready to thread.
- High quality threading oil is necessary to protect die while threading.

3.4 Installing Pipe in Power Threader

- 1) Measure and mark length of pipe being worked.
- 2) If pipe is long enough to be retained by centering device, insert pipe through front or rear of machine. If pipe is short, insert into front of machine.
- 3) Make sure that pipe is centered in centering device, if used, and tighten centering device.
- 4) Tighten Chuck Jaws with a repetitive counterclockwise snap spin of hand wheel. This hammering action tightens Jaws on pipe. A clockwise rotation snap spin releases Jaws.



3.5 Assembly

- A Insert rear leg assembly (6) into tray support ring (3). Make sure lip of tool tray (1) is facing up and away from foot in rear leg assembly and that foot faces away from tray. Lightly hand tighten set screws (4).
- B Place front leg assembly (7) in tool tray (1), aligning holes in tool tray with holes in front leg assembly. Slide tray pin (2) through and set in place by opening "X" washer with pliers and closing around pin.

Repeat for other front leg assembly, making sure lip of tool tray (1) is up and away from foot.

- C Place base assembly (8) upside down on ground and place legs into the holes with front leg assemblies (2) toward handle. Insert leg bolts (5) and secure with nuts and lockwashers (5).
- D Turn stand right side up and straighten tool tray. It may be necessary to place foot on tool tray and exert force to have tray "snap" into place. Readjust and tighten set screw (4) at desired height.

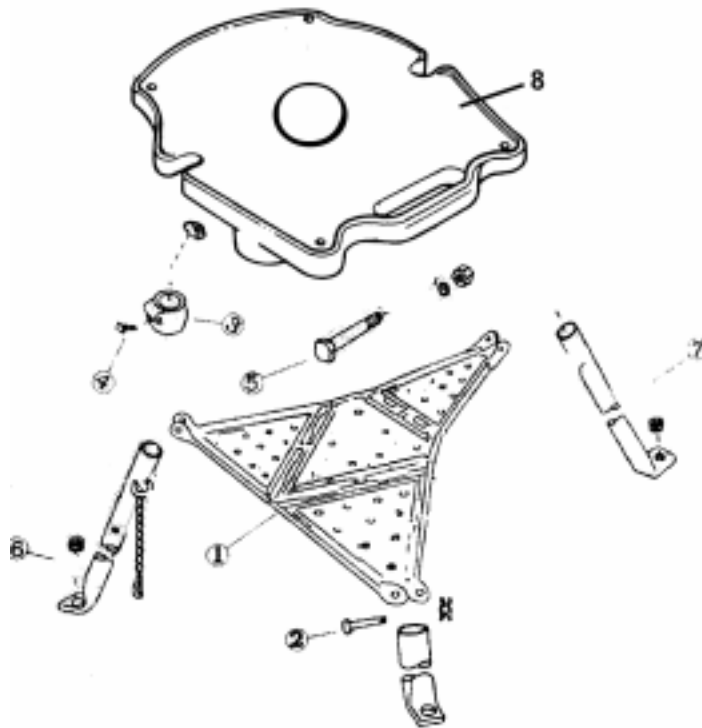

3.6 Locking the Footswitch

We suggest locking the footswitch when leaving the machine unattended. Simply put the footswitch lock rod through the holes on both sides of footswitch and lock it by using a pad lock.

4. Maintenance

IT IS VERY IMPORTANT TO UNPLUG THE POWER CORD BEFORE SERVICING THE POWER THREADER.

1. Use sharp cutting tools.
2. Follow instruction for lubricating and changing accessories.
3. Inspect machine cord. Replace damaged, frayed, broken or worn machine cord.
4. Inspect extension cords. Replace damaged, frayed, broken or worn cords.
5. When not being used, store machine in a secured, locked area, out of reach of children and people unfamiliar with the threading machine.
6. Jaw insert
Jaw insert is a wear item and should be replaced whenever teeth are worn to maintain best gripping power.
Remove
Turn jaw insert 90 degree by putting slotted screwdriver in the slot on the insert
Replace
Turn jaw insert 90 degree to let teeth face up while placing new insert sideways on locking pin and pressing down
7. Motor replacement
Disconnect motor from switch box. Remove two screws holding the motor to the body and loosen one screw close to the main drive output pinion. Carefully lift motor and move out of the body of power threader
8. Motor brush replacement
Check motor brush twice a year. Replace motor brush when is worn to less than 1/2" in length.
9. Lubrication
Main shaft bearings need to be lubricated every 2 months in order to run the power threader trouble-free. Grease fittings are located on the top of machine. High grade of grease is recommended.

5. Accessories

BT-30031 Carriage with Lever

Holds die head, cutter and reamer

BT-30033 Cutter

Full-floating, wheel-type wide roll.

BT-30032 Reamer

Positive locking, 5 flute cone, right hand 1/8" through 2"

BT-30005

Provides effortless power threader portability.

BT-30006C Oiler

Stops oil waste, keeps dies flooded.

BT-334 Stand

Folding with tray

BT-333 Tri-stand Chain Vise

Folding with tray

Exploded View & Parts List



BT-5020 Power Threader

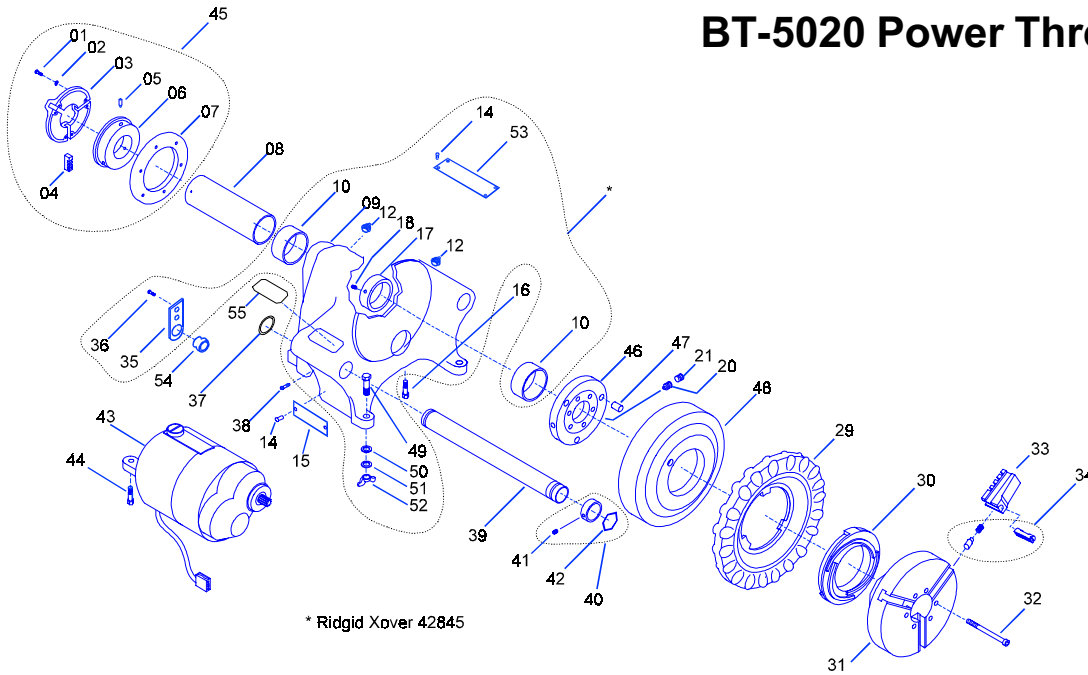

Ref #	Berkley P/N	Qty	Description	Fits Ridge #	Ref #	Berkley P/N	Qty	Description	Fits Ridge #
1	31001	6	Screw		34	30052		Chuck Jaw Set/3 w/inserts	
2	31002	6	Lockwasher # 12			30054	3	Jaw Insert	44715
3	31003	1	Rear Centering Head		35	31035	1	Strain Relief Plate	
4	31004	1	Rear Jaw (set of 3)	46500	36	31036	2	Screw	
5	30004	3	Stop Pin		37	30029	2	Spring Ring	44525
6	31006	1	Rear Scroll		38	31038	2	Screw # 8-32 x 5/8	45280
7	31007	1	Rear Plate		39	30014	2	Support Bar incl. 31037	44425
8	31009	1	Drive Shaft	44100	40	30023	2	Ring Ass'y	44725
9	31009	1	Body		41	31041	2	Set Screw	
10	30002	2	Front/Rear Bearing	45270/45335	42	31042	2	Snap Ring	
11	31011		Front Bearing		43	31043	1	Motor Assembly	87740/3177
12	31012	2	Grease Fitting		44	31044	2	Screw	46745
13	31013		Dowel Pin		45	31045	1	Rear Centering Ass'y	44165
14	31014	10	Pop Rivet		46	31046	1	Drive Ring	
16	31016	1	Screw		47	31047	3	Drive Pin	30022
17	30003	1	Thrust Ring		48	31048	1	Ring Gear	30017
18	31018	2	Set Screw		49	31049	4	Hex Bolt	46670
20	31020	3	Set Screw		50	31050	4	Hex Washer	44230
21	31021	3	Set Screw		51	31051	4	Lock Washer 3/8	40930
29	31029	1	Hand Wheel		52	31052	4	Wing Nut 3/8 - 16	45385
30	31030	1	Scroll		54	73008	1	Cord Grammet	46735
31	31031	1	Cap			BT-30063	1	Reamer Pin	
32	31032	6	Screw			BT-30085	1	Cutter Pin	
33	30051	1	Chuck Jaw Set/3						

Exploded View & Parts List



BT-31043 Power Threader Motor Assembly

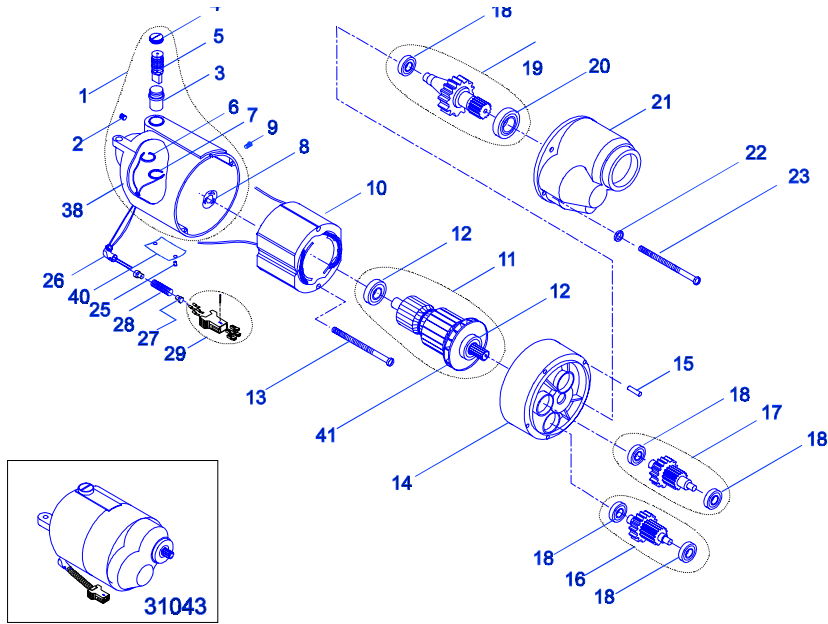

Ref #	Berkley P/N	Qty	Description	Fits Ridge #	Ref #	Berkley P/N	Qty	Description	Fits Ridge #
1	32001	1	Housing Ass'y		15	32015	1	Dowel Pin	
2	32002	2	Set Screw 1/4 - 20 x 1/4	39770	16	32016	1	1st Gear Ass'y	
3	73009	1	Brush Holder set/2	45025	17	32017	1	2nd Gear Ass'y	
4	73011	1	Brush Cap Set/2	44545	18	32018	5	Gear Bearings	
5	73031	1	Brush Set/2	44540	19	30048	1	Drive Gear Ass'y	
6	32006	1	White Upper Lead	86680	20	32020	1	Front Bearing	
7	32001	1	Red Lower Lead	86685	21	32021	1	Gear Housing	
8	32008	1	Loading Spring		22	32022	4	Lock Washer 1/4"	
9	32009	1	Locking Screw 1/4 - 20 x 3/4	83500	23	32023	4	Screw 1/4 - 20 x 3	45075
10	73006	1	Field (115V)	86690	25	32025	2	Pop Rivet	
11	73002	1	Armature (115V)	44010	26	32026	1	90 Deg Connector	
41	73005	1	Armature fan		27	32027	2	Insulator	46890
12	73004	2	Armature Bearing	44565	28	32028	1	Flexible Conduit	
13	32013	2	Mounting Screw # 10 - 24 x 3	44555	29	32029	1	Outlet Jumper	50552
14	32014	1	Fan Housing Ass'y Incl fan plate						

6. Registration form

Please detach and mail back to Berkley Tool Company at
851 Jupiter Park Lane, Jupiter, FL 33458, U.S.A.

Date of Purchase _____

Model # _____

Serial # _____

Place of purchase

Name _____

Address _____

Please keep this portion for your record.

Date of Purchase _____

Model # _____

Serial # _____

Place of purchase

Name _____

Address _____

7. Limited Warranty

Berkley covers its products with one-year warranty against defects in material or workmanship. To take advantage of this warranty, the complete product must be delivered prepaid to Berkley Tool or any Berkley authorized service center. No employee, agent, dealer, or other person is authorized to give any warranty on behalf of Berkley Tool Company. Warranted products will be repaired or replaced, at our option, at no charge to you and returned to you via pre-paid transportation. Such replacement or repair is the exclusive remedy available from Berkley. Berkley is not liable for damage of any sort, including incidental and consequential damages. Some U.S.A. states do not allow the exclusion or limitation of incidental or consequential damages, so the above limitation or exclusion may not apply. This warranty gives you specific legal rights, and you may have other rights, which vary, from state to state.